Standalone Linear Lithium Battery Charger With Thermal Regulation

CE3170 Series

■ INTRODUCTION

The CE3170 is a complete constant-current/constant-voltage linear charger for single cell lithium rechargeable battery. No external sense resistor is needed, and no blocking diode is required due to the internal P-MOSFET architecture. Furthermore, the CE3170 is specifically designed to work within USB power specifications. Its low external component count makes the CE3170 ideally suited for portable applications. Thermal feedback regulates the charge current to limit the die temperature during high power operation or high ambient temperature. The charge current can be programmed externally with a single resistor. The CE3170 automatically terminates the charge cycle when the charge current drops to 3/10th the programmed value after the final float voltage is reached. When the input supply (wall adapter or USB supply) is removed, the CE3170 automatically enters a low power sleep mode, dropping the battery drain current to less than 2 μ A. The CE3170 can be put into shutdown mode, reducing the supply current to 50 μ A. Other features include under voltage lockout, automatic recharge and one status pin to indicate charging and charge termination. The CE3170 is available in thermally enhanced SOT package.

■ APPLICATIONS

- Cellular phones, PDAs
- Portable Media Players
- Digital Still Cameras

■ FEATURES

- Charges Single Cell Lithium Battery Directly from USB Port or AC Adapter
- Input Voltage Range From 4.5V to 28V
- Input OVP: 6.5V
- No External MOSFET, Sense Resistor or Blocking Diode Required
- Preset 4.20V/4.35V/4.40V Charge Voltage
- Continuous Programmable Charge Current Up to 600mA
- Precharge Conditioning for Reviving Deeply Discharged Cells and Minimizing Heat Dissipation during Initial Stage of Charge
- Constant-Current/Constant-Voltage/Constant-Temp Operation with Thermal Regulation to Maximize Charge Rate Without Risk of Overheating
- Battery Reverse Protection
- Automatic Recharge
- Charge state pairs of output, no battery and fault status display
- Charge Current Monitor Output for Gas Gauging
- Automatic Low Power Sleep Mode When Input Supply Voltage is Removed
- Soft-Start Limits Inrush Current

- Bluetooth & GPS Applications
- Mobile Internet Device
- Charging Docks and Cradles

■ ORDER INFORMATION

CE3170① ② ③ ④ ⑤

DESIGNATOR	SYMBOL	DESCRIPTION
①	A	Standard
②③④	Integer	Output Voltage e.g.4.20V=②: 4, ③: 2, ④: 0
⑤	M	Package: SOT-23-5

■ PIN CONFIGURATION

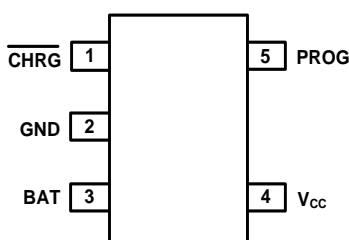

SOT-23-5(Top View)

Table 1. Pin Description (SOT-23-5)

PIN NO.	PIN NAME	FUNCTION
1	$\overline{\text{CHRG}}$	Open Drain Charge Status Output. When the battery is being charged, the $\overline{\text{CHRG}}$ pin is pulled low by an internal switch, otherwise $\overline{\text{CHRG}}$ pin is in high impedance state.
2	GND	Ground Terminal.
3	BAT	Charger Power Stage Current Output and Battery Voltage Sense Input. BAT pin provides charge current to the battery and regulates the final float voltage. An internal precision resistor divider from this pin sets the float voltage which is disconnected in shutdown mode. Connect the positive terminal of the battery to BAT pin. Bypass BAT to GND with 10 μ F to 47 μ F capacitor. BAT pin draws less than 2 μ A current in chip disable mode or in sleep mode.
4	V _{CC}	Positive Input Supply Voltage. V _{CC} is the power supply to the internal circuit. V _{CC} can range from 4.5V to 24V and should be bypassed with at least a 4.7 μ F capacitor. When V _{CC} drops to within 80mv of the BAT pin voltage or V _{CC} >V _{OVp} , CE3170 enters low power sleep mode, dropping BAT pin's current to less than 2 μ A.
5	PROG	Constant Charge Current Setting and Charge Current Monitor Pin. The charge current is set by connecting a 1% accuracy metal film resistor R _{PROG} from this pin to GND. When charging in precharge mode, the PROG pin voltage is regulated to 0.3V. When charging in constant-current mode, the PROG pin voltage is regulated to 1V. In all modes during charging, the voltage on PROG pin can be used to measure the charge current as the following formula: I_{BAT}=(V_{PROG}/R_{PROG})×1000

■ BLOCK DIAGRAM

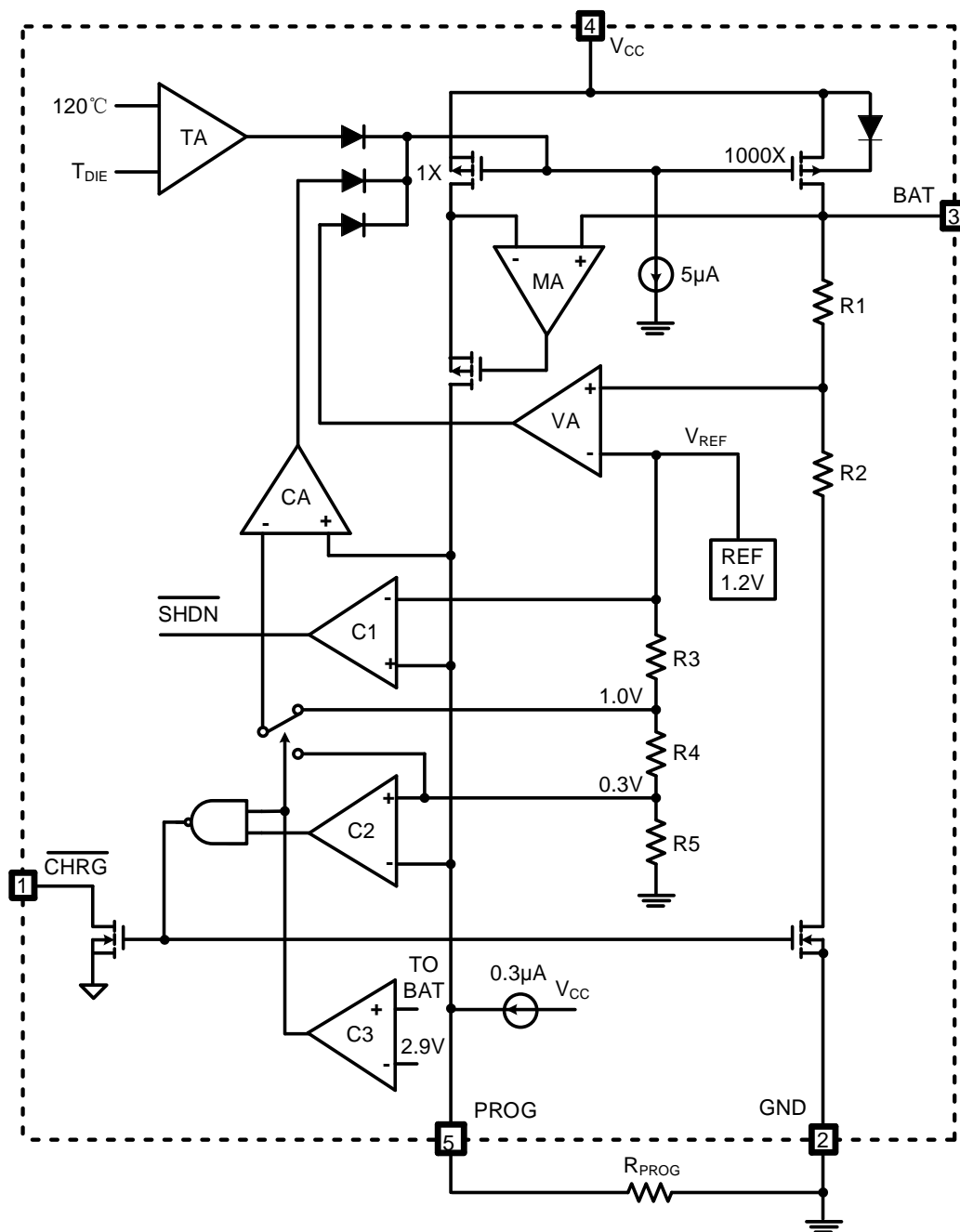

Figure 1 Functional Block Diagram

■ ABSOLUTE MAXIMUM RATINGS⁽¹⁾

(Unless otherwise specified, $T_A = 25^\circ\text{C}$)

PARAMETER	SYMBOL	RATINGS	UNITS
Input Supply Voltage ⁽²⁾	V_{CC}	-0.3 ~ 33	V
PROG Pins Voltage ⁽²⁾		-0.3 ~ 7.0	
BAT Pin Voltage ⁽²⁾		-5 ~ 12	
$\overline{\text{CHRG DONE}}$ Pins Voltage ⁽²⁾		-0.3 ~ 33	
BAT Short-Circuit Duration	-	Continuous	-
BAT Pin Output Current (Continuous)	I_{BAT}	800	mA
Output sink current	$I_{\text{CHRG}}, I_{\text{DONE}}$	10	mA
Power dissipation	P_D	400	mW
Operating Ambient Temperature Range ⁽³⁾	T_A	-40 ~ +85	°C
Junction Temperature	T_J	-40 ~ +150	
Storage Temperature	T_{stg}	-55 ~ +150	
Lead Temperature (Soldering, 10s)	T_{solder}	260	
ESD rating ⁽⁴⁾	HBM	≥ 2000	V
	MM	≥ 200	

(1) Stresses beyond those listed under absolute maximum ratings may cause permanent damage to the device. These are stress ratings only, and functional operation of the device at these or any other conditions beyond those indicated under recommended operating conditions is not implied. Exposure to absolute-maximum-rated conditions for extended periods may affect device reliability.

(2) All voltages are with respect to network ground terminal.

(3) The CE3170 are guaranteed to meet performance specifications from 0°C to 70°C . Specifications over the -40°C to 85°C operating temperature range are assured by design, characterization and correlation with statistical process controls.

(4) The human body model is a 100pF capacitor discharged through a 1.5k Ω resistor into each pin. The machine model is a 200pF capacitor discharged directly into each pin.

■ RECOMMENDED OPERATING CONDITIONS

PARAMETER	SYMBOL	MIN	MAX	UNITS
Input voltage range ⁽⁵⁾	V_{CC}	4.5	28	V
BAT Pin Output Current (Continuous)	I_{BAT}	20	600 ⁽⁶⁾	mA
Fast-charge current programming resistor ⁽⁷⁾	R_{PROG}	1.66	50	k Ω

(5) If V_{CC} is between UVLO and 4.5V, and above the battery voltage, then the IC is active (can deliver some charge to the battery), but the IC will have limited or degraded performance (some functions may not meet data sheet specifications). The battery may be undercharged (V_{FLOAT} less than in the specification), but will not be overcharged (V_{FLOAT} will not exceed specification).

(6) The thermal regulation feature reduces charge current if the IC's junction temperature reaches 125°C ; thus without a good thermal design the maximum programmed charge current may not be reached.

(7) Use a 1% tolerance metal film resistor for R_{PROG} to avoid issues with the R_{PROG} short test when using the maximum charge current setting.

■ ELECTRICAL CHARACTERISTICS

($V_{CC} = 5V$, $T_A = 25^\circ C$, Test Circuit Figure2, unless otherwise specified)

PARAMETER	SYMBOL	CONDITIONS	MIN	TYP	MAX	UNITS
Input Voltage Tolerance					28	V
Input Over-Voltage Protection Voltage	V_{ovp}	V_{CC} Rising, Hys = 0.27V	6.1	6.5	6.9	V
Input Voltage Range for Charging			4.5		6.0	V
V_{CC} Under voltage Lockout Threshold	V_{UVL}	V_{CC} from Low to High		3.9		V
V_{CC} Under voltage Lockout Hysteresis	ΔV_{UVL}			150		mV
Input Supply Current	I_{CC}	Charge Mode, $R_{PROG} = 10K$		150	500	μA
		Standby Mode (Charge Terminated)		90	180	
		Shutdown Mode: R_{PROG} Not Connected, $V_{CC} < V_{BAT}$, or $V_{CC} < V_{UVL}$		50	100	
Trickle Charge Threshold	V_{TRIKL}	$R_{PROG} = 10K$, V_{BAT} Rising		2.9		V
Trickle Charge Hysteresis	ΔV_{TRIKL}	$R_{PROG} = 10K$		100		mV
Trickle Charge Current	I_{TRIKL}	$R_{PROG} = 2K$	135	150	165	mA
BAT Pin Current	I_{BAT}	$R_{PROG} = 2K$, Current Mode($V_{BAT} = 4.0V$)	450	500	550	μA
		Standby Mode, $V_{BAT} = V_{FLOAT}$	0	-2.0	-6.0	
		Shutdown Mode (R_{PROG} Not Connected)		0	± 2	
		Sleep Mode, $V_{CC} = 0V$		0	-1	
PROG Pin Voltage	V_{PROG}	$R_{PROG} = 1K$, Current Mode	0.9	1.0	1.1	V
PROG Pin Pull-Up Current	I_{PROG}			0.3		μA
Regulated Output (Float) Voltage	V_{FLOAT}	$0^\circ C \leq T_A \leq 85^\circ C$, $I_{BAT} = 45mA$, $R_{PROG} = 10K$	4.158	4.200	4.250	V
			4.300	4.350	4.400	V
			4.350	4.400	4.450	V
3C/10 Termination Current Threshold	I_{TERM}	$R_{PROG} = 2K$		150		mA

■ ELECTRICAL CHARACTERISTICS(continued)

($V_{CC} = 5V$, $T_A = 25^\circ C$, Test Circuit Figure2, unless otherwise specified)

PARAMETER	SYMBOL	CONDITIONS	MIN	TYP	MAX	UNITS
Recharge Battery Threshold	ΔV_{RECHG}	$V_{FLOAT} - V_{RECHG}$		150		mV
Recharge Comparator Filter Time	$t_{RECHARGE}$	V_{BAT} High to Low		0.5		mS
$V_{CC} - V_{BAT}$ Lockout Threshold	A_{MSD}	V_{CC} from Low to High		100		mV
		V_{CC} from High to Low		80		mV
\overline{CHRG} Pin Voltage	$V_{\overline{CHRG}}$	$I_{\overline{CHRG}} = 5mA$		0.5		V
Power FET "ON" Resistance (Between V_{CC} and BAT)	R_{ON}	$I_{BAT} = 600mA$		1000		$m\Omega$
Junction Temperature in Constant Temperature Mode	$T_{J(REG)}$			140		$^\circ C$

■ TYPICAL APPLICATION CIRCUIT

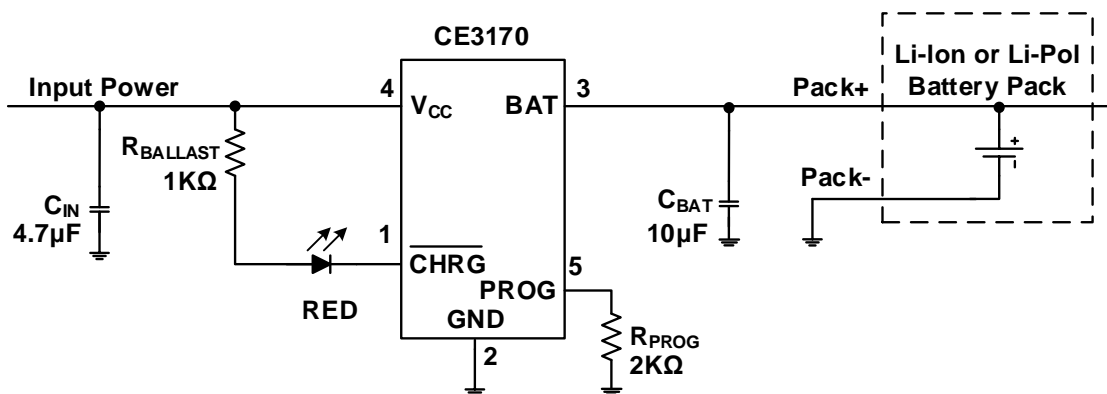

Figure 2 Standard Application Circuit

■ FUNCTIONAL DESCRIPTION

The CE3170 series are highly integrated Li-Ion or Li-Pol linear battery chargers, targeted at space-limited portable applications. It operates from either a USB port or Wall Adapter and charges a single-cell Li-Ion or Li-Pol battery with up to 600mA of charge current.

The charge current is programmable using external components (R_{PROG} resistor). The charge process starts when an external input power is connected to the system, $V_{\text{CC}} > V_{\text{UVL}}$, $V_{\text{CC}} > V_{\text{BAT}} + V_{\text{(SLP_EXIT)}}$, the charger is enabled by the RPROG resistor connected and the battery voltage is below the recharge threshold, $V_{\text{BAT}} < V_{\text{RECHG}}$.

When the charger is enabled two control loops modulate the battery switch drain to source impedance to limit the BAT pin current to the programmed charge current value (charge current loop) or to regulate the BAT pin voltage to the programmed charge voltage value (charge voltage loop). If $V_{\text{BAT}} < V_{\text{TRIKL}}$ (2.9V typical), the BAT pin current is internally set to 3/10th of the programmed fast-charge current value in current regulation mode.

The CE3170 series provide battery charge status via $\overline{\text{CHRG}}$ status pin. $\overline{\text{CHRG}}$ pin is internally connected to an N-channel open drain MOSFET.

The open drain status output that is not used should be tied to ground.

The following table lists the indicator status and its corresponding charging state.

Table 1. Charge Status Indicator ⁽¹⁾

Charge State Description	$\overline{\text{CHRG}}$
Preconditioning-Current Mode (Trickle) Charge	ON
Constant-Current Mode (Fast) Charge	ON
Constant-Voltage Mode (Taper) Charge, $I_{\text{BAT}} > I_{\text{TERM}}$	ON
Charge Termination ($I_{\text{BAT}} < I_{\text{TERM}}$, Charge Done)	HI-Z
Power Down (Undervoltage Lockout) Mode	HI-Z
Sleep Mode ($V_{\text{UVL}} < V_{\text{CC}} < V_{\text{BAT}} + V_{\text{(SLP_EXIT)}}$, or the V_{CC} is removed)	HI-Z
Shutdown Mode (PROG pin floating)	HI-Z
OVP Mode ($V_{\text{CC}} > V_{\text{OVP}}$)	HI-Z
No battery with Charge Enabled	FLASH Rate depends on C_{BAT}
Fault Condition (Battery Short Circuit)	ON

(1) Pulse loading on the BAT pin may cause the IC to cycle between Done and charging states (LEDs Flashing)

■ TYPICAL PERFORMANCE CHARACTERISTICS

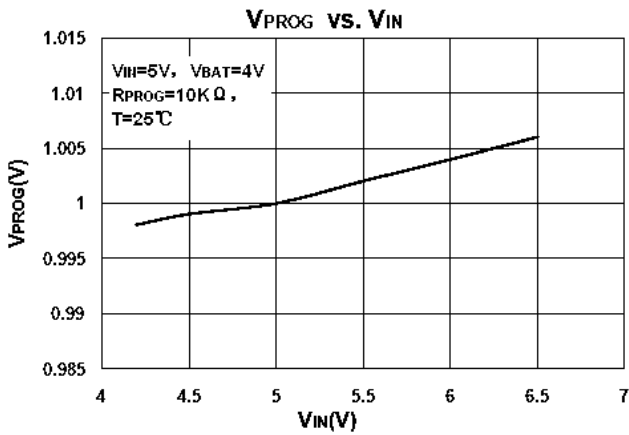

Figure 3

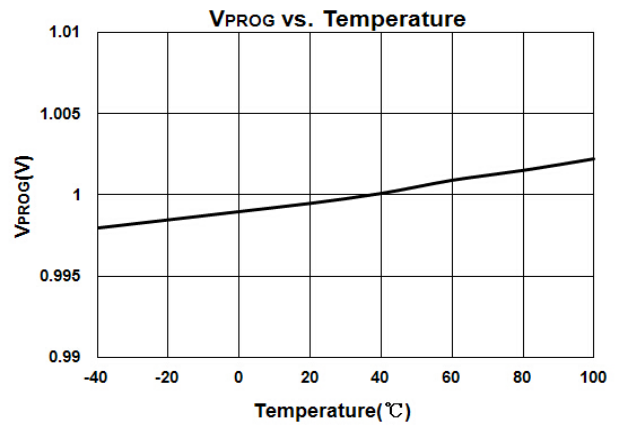

Figure 4

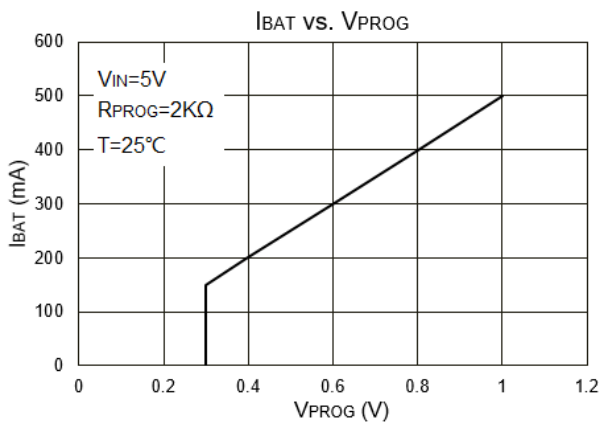

Figure 5

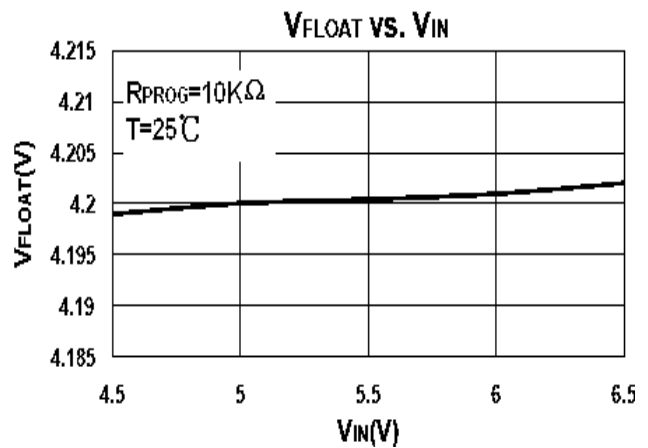

Figure 6

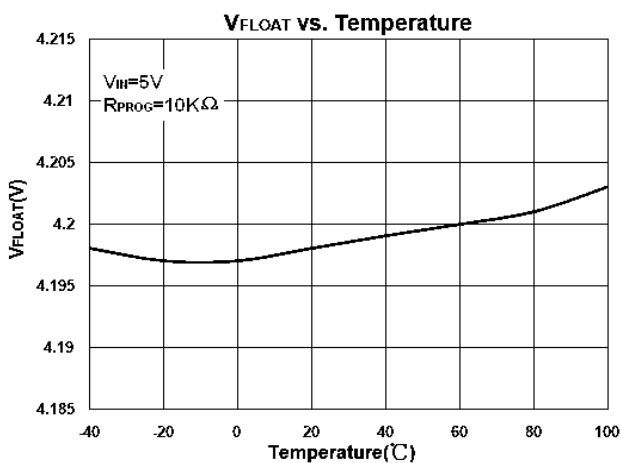

Figure 7

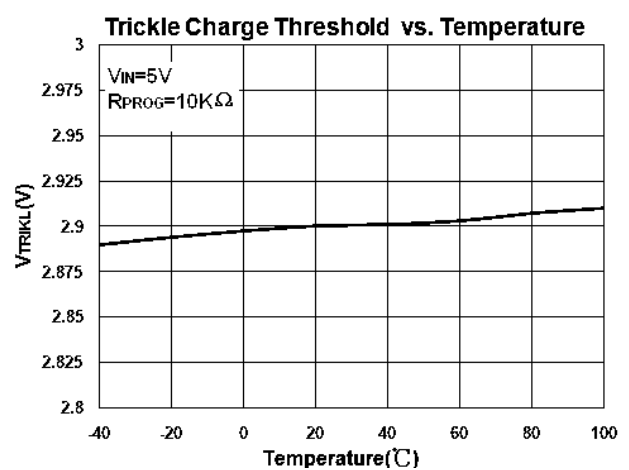
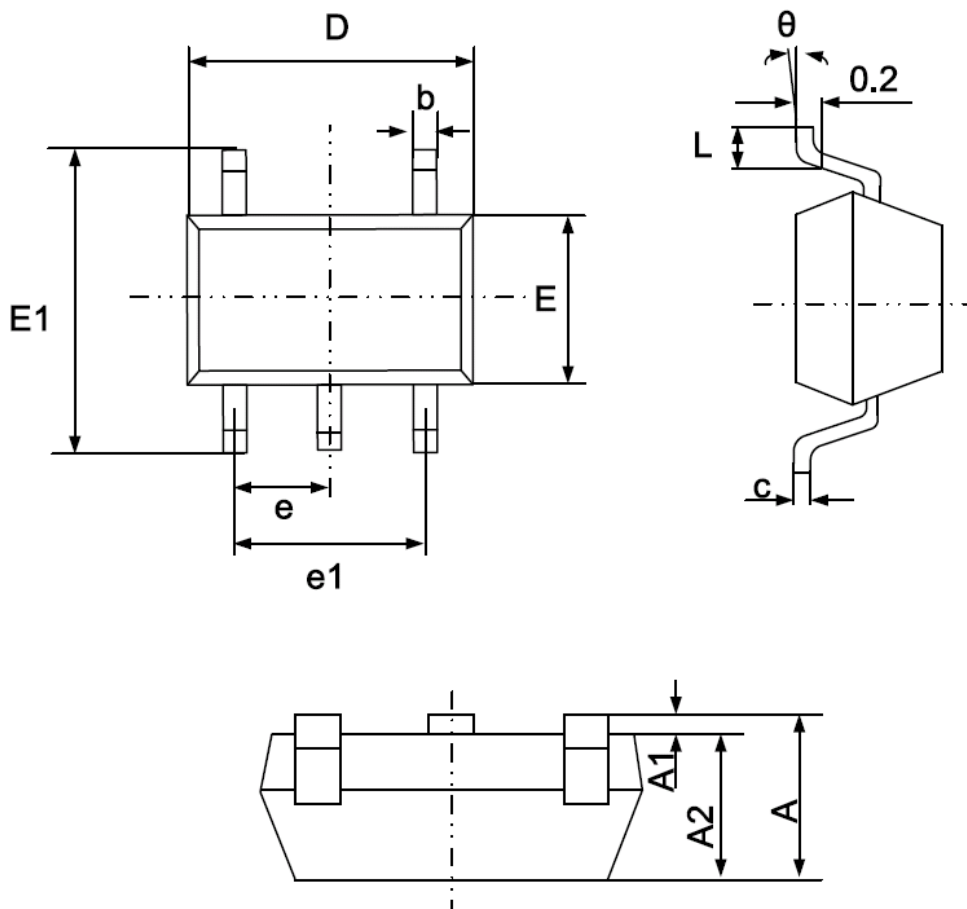

Figure 8

■ PACKAGING INFORMATION

- SOT-23-5 Package Outline Dimensions



Symbol	Dimensions In Millimeters		Dimensions In Inches	
	Min	Max	Min	Max
A	1.050	1.250	0.041	0.049
A1	0.000	0.100	0.000	0.004
A2	1.050	1.150	0.041	0.045
b	0.300	0.500	0.012	0.020
c	0.100	0.200	0.004	0.008
D	2.820	3.020	0.111	0.119
E	1.500	1.700	0.059	0.067
E1	2.650	2.950	0.104	0.116
e	0.950(BSC)		0.037(BSC)	
e1	1.800	2.000	0.071	0.079
L	0.300	0.600	0.012	0.024
theta	0°	8°	0°	8°

© Nanjing Chipower Electronics Inc.

Chipower cannot assume responsibility for use of any circuitry other than circuitry entirely embodied in a Chipower product. No circuit patent license, copyrights or other intellectual property rights are implied. Chipower reserves the right to make changes to their products or specifications without notice. Customers are advised to obtain the latest version of relevant information to verify, before placing orders, that information being relied on is current and complete.